

TEMPLATE

AN ELEGANT SYSTEM | FOR PRIVATE SPACE

Form Friendly shapes follow the ebb and flow of work. Comfort in the right measure of human scale for private space.

Capacity Storage, power and communications are accessible everywhere above and below perimeter worksurfaces. Think, sit, stand, meet or move freely within minimal space.

Modularity A set of rearrangeable building blocks hug the walls to preserve open space. Elements may be added, subtracted, or reconfigured to afford lasting flexibility. Tables dock, projects nest, and storage rolls below to accommodate frequent change.

P5

Design: Metro Design Group

office size = 10'-6" x 12'-6"
work surface = 3776 sq."
shelf storage = 300"
filing = 130"

Products featured:

Worksurfaces

- straight perimeter core unit
- extension arc desk

Storage

- modular pedestals
- double height overheads with doors
- double height overheads with doors and open shelf
- storage cabinet
- Highboy

Seating

- Cambria executive chair
- Ventura side chair

Other products featured

- DesignTex™ fabrics

> Highboy

Stand-up height meeting/worksurface includes open shelf and cubby with secured storage below.

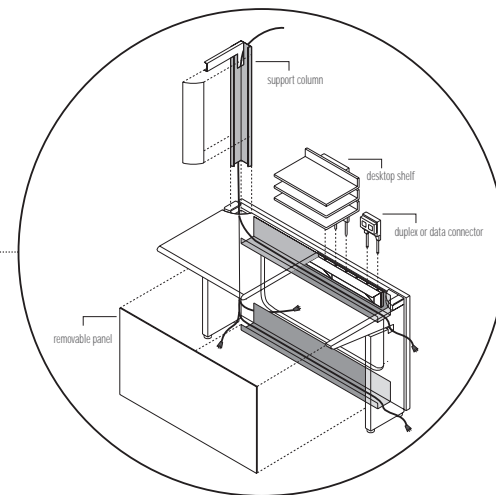
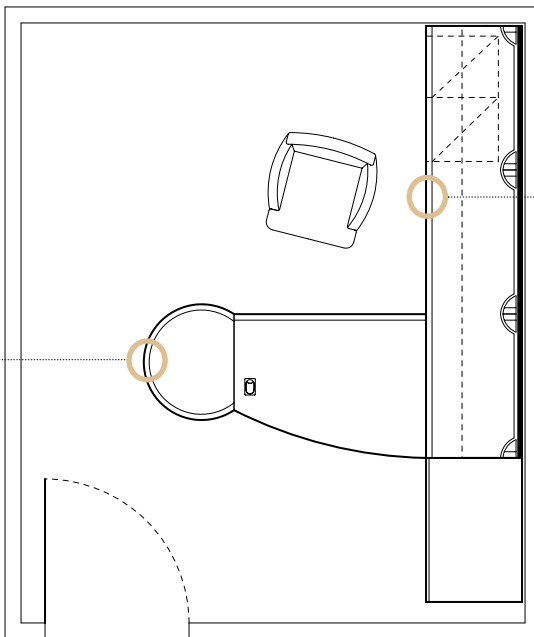
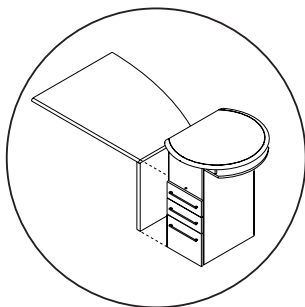

> Cable Management & Workspace Connectivity

above: Support columns provide vertical wire distribution from the perimeter core unit to overhead storage.

below: Openings in support panels allow wires to pass from section to section. Channels under desk surface and at base provide horizontal wire distribution. Lightweight, removable panels enable full access to utilities at perimeter wall.

